



2-port valves
VVP47..(S)



3-port valves
VXP47..



3-port valves with bypass
VMP47..(S)

Acvatix™

2-port and 3-port terminal unit valves PN16

VVP47..(S)
VXP47..
VMP47..(S)

- Bronze valve body CC491K (Rg5) max. 4% Pb
- DN 10, DN 15 and DN 20
- k_{vs} 0.25 to 4 m³/h
- Linear characteristic
- Flat seal male threaded connections G..B to ISO 228-1
- V..P47..S valves: Male threaded connections for use with Conex compression fittings for copper pipes
- Manual adjuster
- Can be combined with SSP.., SFP.. electromotoric actuators or STP..3.. electrothermal actuators

Use

- For use in ventilation and air conditioning systems for water-side terminal unit control in closed circuits, e.g. for induction units, fan coil units, small re-heaters and small coolers.
 - 2-pipe systems with 1 heat exchanger for heating and cooling
 - 4-pipe systems with 2 separate heat exchangers for heating and cooling
- In closed-circuit zone heating systems, e.g. for:
 - Separate floors in a building
 - Apartments and individual rooms
- The VXP47..S 3-port valves together with SFP.. actuators are specially suited for changeover applications where small leakage rates are required.

Type summary

VVP47.. ¹⁾ 2-port	VVP47..S ²⁾ 2-port	VXP47.. ¹⁾ 3-port	VMP47.. ¹⁾ 3-port with bypass	VMP47..S ²⁾ 3-port with T-bypass	DN	k _{vs} A → AB [m ³ /h]	k _{vs} ³⁾ B → AB [m ³ /h]
VVP47.10-0.25		VXP47.10-0.25	VMP47.10-0.25		10	0,25	0,18
VVP47.10-0.4		VXP47.10-0.4	VMP47.10-0.4			0,40	0,28
VVP47.10-0.63	VVP47.10-0.63S	VXP47.10-0.63	VMP47.10-0.63	VMP47.10-0.63S		0,63	0,44
VVP47.10-1	VVP47.10-1S	VXP47.10-1	VMP47.10-1	VMP47.10-1S		1,00	0,70
VVP47.10-1.6	VVP47.10-1.6S	VXP47.10-1.6	VMP47.10-1.6	VMP47.10-1.6S		1,60	1,12
VVP47.15-2.5	VVP47.15-2.5S	VXP47.15-2.5	VMP47.15-2.5	VMP47.15-2.5S	15	2,50	1,75
VVP47.20-4		VXP47.20-4			20	4,00	2,80

¹⁾ Flat seal male threaded connections

²⁾ Male threaded connections for use with Conex compression fittings

³⁾ Applies only to 3-port version

k_{vs} = nominal flow rate of cold water (5...30 °C) through the fully opened valve (H₁₀₀) at a differential pressure of 100 kPa (1 bar)

Accessories

Prod. No.	Stock no.	Description
ALG..2	ALG..2	Set of 2 fittings with threaded connections for 2-port valves or 3-port valves with bypass, consisting of: 2 union nuts, 2 discs and 2 flat seals ALG..3B are brass fittings, for media temperatures up to 100 °C.
ALG..2B	S55846-Z1..	
ALG..3	ALG..3	Set of 3 fittings with threaded connections for 3-port valves, consisting of: 3 union nuts, 3 discs and 3 flat seals ALG..3B are brass fittings, for media temperatures up to 100 °C.
ALG..3B	S55846-Z1..	
AL50	AL50	For mounting SFP.. actuators on zone valve V..P47..

Ordering

Please give valve and the required ALG.. threaded fittings. The ALG.. threaded fittings, the SSP.., SFP.. and STP..3.. actuators as well as the supporting ring AL50 (needed for combination with SFP..) must be ordered as separate items.

Example:

Product number	Stock number	Description	Quantity
VXP47.10.1	VXP47.10.1	3-port Terminal Unit Valve PN16	4
ALG133	ALG133	Threaded Fittings	4

For 3-port valves with bypass VMP47.. order two sets of ALG..2 or ALG..2B threaded fittings.

Delivery

Valves, actuators and fittings are packed and supplied separately.

Equipment combinations

Valves	Electromotoric actuators				Electrothermal actuators	
	SSP..		SFP..		STP..3..	
	Δp_{\max}	Δp_s	Δp_{\max}	Δp_s	Δp_{\max}	Δp_s
	[kPa]	[kPa]	[kPa]	[kPa]	[kPa]	[kPa]
VVP47.10-0.25...0.4	400	1000	400	1000	400	700
VVP47.10-0.63...1(S)		500		500	250	250
VVP47.10-1.6(S)	300	300	300	300	150	150
VVP47.15-2.5(S)		300		300		
VVP47.20-4	175	175	175	175	100	100
VXP47.10-0.25...0.4	400		400		400	
VXP47.10-0.63...1					250	
VXP47.10-1.6	300		300		150	
VXP47.15-2.5			300		150	
VXP47.20-4	175	175	100			
VMP47.10-0.25...0.4	400		400		400	
VMP47.10-0.63...1(S)					250	
VMP47.10-1.6(S)	300		300		150	
VMP47.15-2.5(S)			300		150	
Data sheet	N4864		N4865		N4884	

Δp_{\max} = maximum permissible differential pressure across the control path of the valve valid for the entire actuating range of the motorized valve

Δp_s = maximum permissible differential pressure (close of pressure) at which the motorized valve will close securely against the pressure

Overview of actuators

Actuator	Type of actuator	Operating voltage	Positioning signal	Positioning time	Positioning force
SSP31	Electromotoric	AC 230 V	3-position	150 s	160 N
SSP81		AC 24 V		43 s	
SSP81.04		AC / DC 24 V		34 s	
SSP61		AC 230 V	2-position	10 s	135 N
SFP21/18		AC 24 V			
SFP71/18					
STP23	Electrothermal	AC 230 V	2-position	210 s	100 N
STP73		AC / DC 24 V	2-position	270 s	
STP73PR/00 ³⁾			2-position / PDM ¹⁾		
STS63		AC 24 V	DC 0...10 V	270 s ²⁾	

¹⁾ PDM = Pulse-Duration-Modulation

²⁾ refer to data sheet N4880 for details

³⁾ Variant for PDM and parallel flow

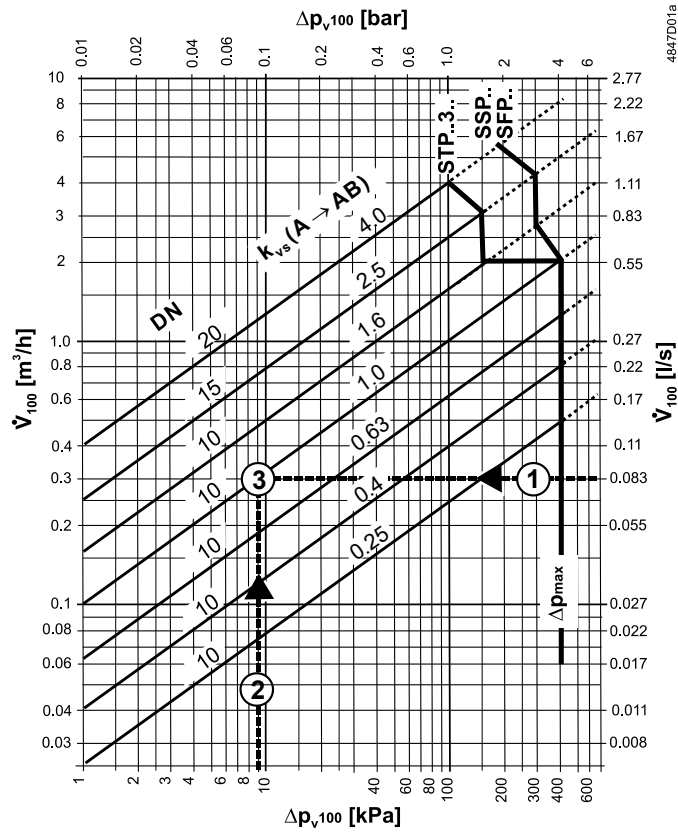

Example:

- 1 $\dot{V}_{100} = 0.083 \text{ l/s}$
- 2 $\Delta p_{V100} = 9 \text{ kPa}$
- 3 Required k_{vs} -value = $1.0 \text{ m}^3/\text{h}$

- Δp_{V100} = differential pressure across the fully open valve and control path A → AB by a volume flow \dot{V}_{100}
- \dot{V}_{100} = volume flow through the fully open valve (H_{100})
- Δp_{max} = maximum permissible differential pressure across the valve's control path, valid for the entire actuating range of the motorized valve
- 100 kPa = 1 bar ≈ 10 mWC
- 1 m^3/h = 0.278 l/s water at 20 °C

Valve characteristics

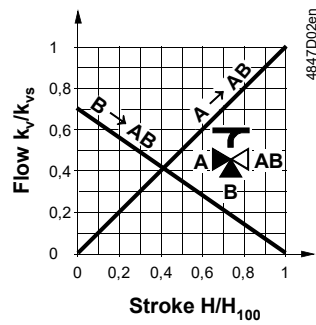

With valve types VXP47../VMP47..(S), the K_{vs} values in bypass B represent only 70 % of the K_{vs} value in the straight-through control path, A → AB. This compensates for the flow resistance of the heat exchanger or radiator, so keeping the overall flow rate, \dot{V}_{100} as constant as possible.

Mechanical design







- Combined disc / plug flow restrictor
- Seat ring embedded in through-port A → AB
- Seat machined into bypass B → AB.
- Continuously lubricated sealing rings
- Conical return springs, for more compact valve construction

Engineering notes

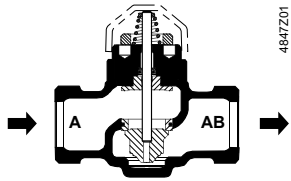
Also refer to "Mounting notes" and "Commissioning", page 7.

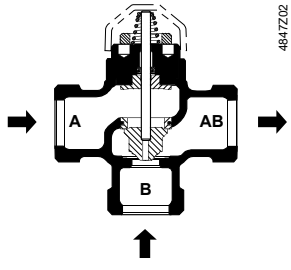
The 2-port valves should preferably be installed in the return, where the stem seal will be exposed to lower temperatures.

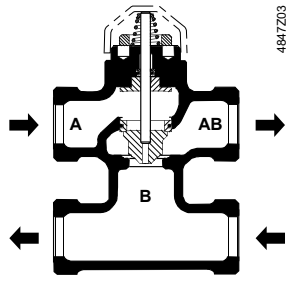
Recommendation: A strainer should be fitted upstream of the valve. This increases reliability.

Valve construction	Valve series	Valve flow in control mode			Valve stem	
		Inlet A	Inlet B	Outlet AB	Retracted	Extended
<p>2-port valves</p> 	<p>VVP47..(S)</p> 	variable		variable	<p>A → AB opens</p>	<p>A → AB closes</p>
<p>3-port valves</p> 	<p>VXP47..</p> 	variable	variable	constant	<p>A → AB opens</p>	<p>A → AB closes</p>
<p>3-port valves with bypass</p> 	<p>VMP47.. (S)</p> 	variable	variable	constant	<p>A → AB opens</p>	<p>A → AB closes</p>

Warning

The direction of flow **MUST** be as indicated by the arrow, i.e. only from A → AB and B → AB.

The 3-port valve types VXP47.. and VMP47..(S) may only be used in mixing applications.

Mounting notes

Orientation

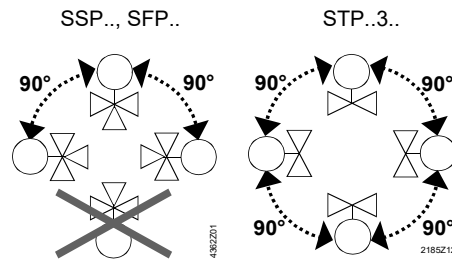

The specified direction of flow must be observed in all cases, also refer to "Engineering notes", page 5.

The valves are delivered in single packs; Mounting Instructions 74 319 0301 0 are enclosed with the packaging.

The valve and actuator can be easily assembled on site. There is no need for special tools or calibration.

AL50 supporting ring

The AL50 supporting ring must be put into position before mounting the actuator SFP.. onto the valve. Only the equipment combination V..P47.. and SFP.. requires supporting ring AL50.

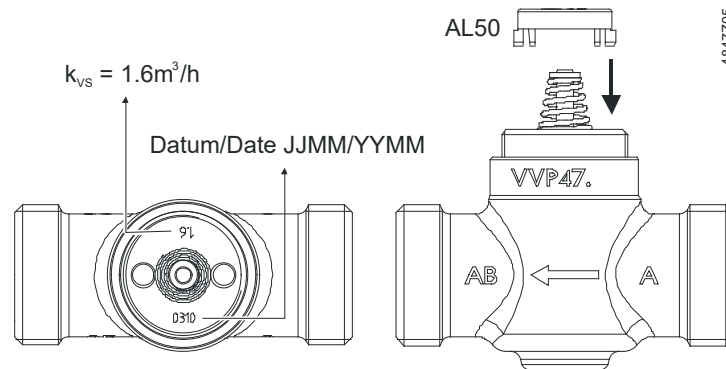

Commissioning



Commission the valve only if the manual knob or actuator have been mounted correctly.

Manual adjustment

The straight-through control path A → AB can be opened either electrically via the actuator, or by adjustment with the manual button. In the case of 3-port valves, this throttles or closes bypass B.

Maintenance

Warning

V..P47..(S) valves require no maintenance.

When doing service work on the valve / actuator:

- Deactivate the pump and turn off the power supply
- Close the shutoff valves
- Fully reduce the pressure in the piping system and allow pipes to completely cool down

If necessary, disconnect the electrical wires.

Before putting the valve into operation again, make certain the manual knob or the actuator is correctly fitted.

Stem sealing gland

The stem sealing gland cannot be exchanged. In the case of leakage, the entire valve must be replaced. Contact your local office or branch.

Disposal

Do not dispose of the device as household waste.

Warning

Due to the tensioned spring return, valve disassembly may result in flying parts causing possible injury.

Only authorized staff may disassemble valves with tensioned spring return!

Disposal

- Special handling of individual components may be mandated by law or make ecological sense.
- Observe all local and currently applicable laws and regulations.

Warranty

The technical data supplied for these valves is valid only for valves used in conjunction with the actuators listed under "Equipment combinations", page 3.

Use with third-party actuators invalidates any warranty offered by Siemens Switzerland Ltd / HVAC Products.

Technical data

Operating data	PN class	PN 16 to EN 1333
	Permissible operating pressure	1600 kPa (16 bar)
	Valve characteristic	
	Path A → AB	linear
	Bypass B → AB	linear
	Leakage rate	to DIN EN 1349
	Path A → AB	0...0.05 % of k_{vs} value
	Bypass B → AB	0...0.05 % of k_{vs} value
	Permissible media	chilled water, low-temperature hot water and water with frost protection additives recommendation: water should be treated as specified in VDI 2035
	Temperature of medium	1...110 °C, or max. 120 °C for short periods ¹⁾
Rangeability S_v	> 50 as in VDI 2173	
Nominal stroke	2.5 mm	
Standards, directives and approvals	Pressure Equipment Directive	PED 2014/68/EU
	Pressure Accessories	Scope: Article 1, section 1 Definitions: Article 2, section 5
	Fluid group 2	without CE-marking as per article 4, section 3 (sound engineering practice) ²⁾
	EAC Conformity	Eurasia Conformity
Environmental compatibility	The product environmental declaration CE1E4847en ³⁾ contains data on environmentally compatible product design and assessments (RoHS compliance, materials composition, packaging, environmental benefit, disposal).	

¹⁾ ALG..B fittings for media temperatures up to 100 °C

²⁾ Valves where $PS \times DN < 1000$, do not require special testing and cannot carry the CE label.

³⁾ The documents can be downloaded from <http://siemens.com/bt/download>.

S_v = rangeability k_{vs} / k_{vr}

k_{vs} = nominal flow rate of chilled water (5...30 °C) through the fully opened valve (H_{100}) at a differential pressure of 100kPa (1bar).

k_{vr} = the lowest value for k_v at which the flow characteristic tolerance is still maintained, at a differential pressure of 100kPa (1 bar)

Materials	Valve body	bronze CC491K (Rg5) max. 4% Pb
	Stem	stainless steel
	Plug, seat ring, gland	brass
	Stem seal	EPDM O-rings
Dimensions / weight	Dimensions	refer to "Dimensions", page 10
	Threaded connections (V..P47..)	
	Valve	G..B to ISO 228-1
	Threaded fittings	R/Rp.. to ISO 7-1, G.. to ISO 228-1
	Threaded connections (V..P47..S)	
	Valve DN 10	G..B to ISO 228-1
	Valve DN 15	W1 $\frac{1}{8}$ -14 to BS84
Actuator connection	M30 x 1.5	
Weight	refer to "Dimensions", page 10	
Accessories	ALG..2, ALG..3 threaded fittings (supplier: Siemens)	nut, nipple and flat seal for steel pipes with gas- pipe threads
	SERTO SO 00021.. threaded fittings (available from suppliers to the trade)	nut and compression fitting for seamless copper and mild-steel piping
	Welded fittings (available from suppliers to the trade)	for copper and steel piping

Dimensions

2-port valves VVP47..

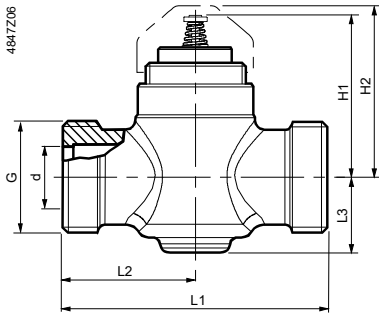

3-port valves VXP47..

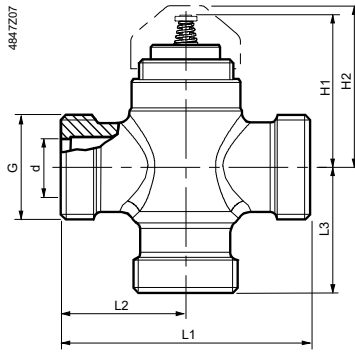

3-port valves with bypass VMP47..

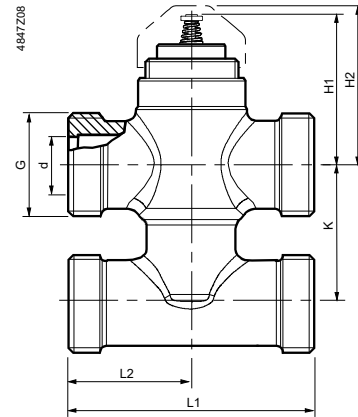

2-port valves VVP47..(S)

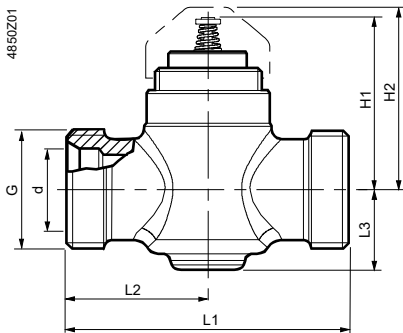

3-port valves with T-bypass VMP47..(S)

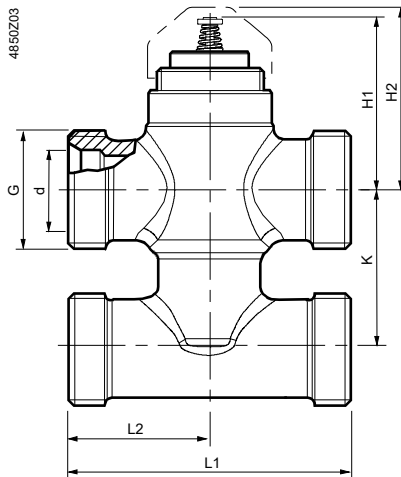

Product number	DN	G [Inch]	d [mm]	H1 [mm]	H2 [mm]	L1 [mm]	L2 [mm]	L3 [mm]	Weight [kg]
VVP47.10-0.25...1.6	10	G½B	10.5	46	≈ 49	60	30	19	0.32
VVP47.10-0.63S ... 1.6S	10	G½B	15.2	46	≈ 49	60	30	19	0.32
VVP47.15-2.5	15	G¾B	14	46	≈ 49	65	32.5	19	0.34
VVP47.15-2.5S	15	W1½-14	22.2	46	≈ 49	65	32.5	19	0.34
VVP47.20-4	20	G1B	20	49	≈ 52	80	40	23	0.44

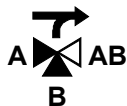

Product number	DN	G [Inch]	d [mm]	H1 [mm]	H2 [mm]	L1 [mm]	L2 [mm]	L3 [mm]	Weight [kg]
VXP47.10-0.25...1.6	10	G½B	10.5	46	≈ 49	60	30	30	0.32
VXP47.15-2.5	15	G¾B	14	46	≈ 49	65	32.5	32.5	0.37
VXP47.20-4	20	G1B	20	49	≈ 52	80	40	40	0.5



Product number	DN	G [Inch]	d [mm]	H1 [mm]	H2 [mm]	K [mm]	L1 [mm]	L2 [mm]	Weight [kg]
VMP47.10-0.25...1.6	10	G½B	10.5	46	≈ 49	40	60	30	0.4
VMP47.10-0.63S ... 1.6S	10	G½B	15.2	46	≈ 49	40	60	30	0.4
VMP47.15-2.5	15	G¾B	14	46	≈ 49	40	65	32.5	0.48
VMP47.15-2.5S	15	W1½-14	22.2	46	≈ 49	40	65	32.5	0.48

Sets of threaded fittings
with
flat seal:
Set of 2
(for V..P47..)

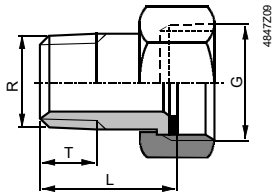

Prod. no. /stock no.	Prod. No. Stock no.	Connection pipe side	G [Inch]	Rp [Inch]
ALG132		External thread	G ½	R ⅜
ALG142		External thread	G ¾	R ½

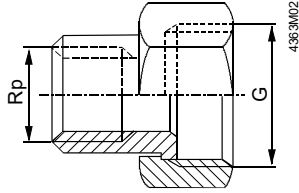

ALG122		Internal thread	G ¾	Rp ⅜
ALG152	ALG152B S55846-Z100	Internal thread	G 1	Rp ½

Set of 3
(for V..P47..)

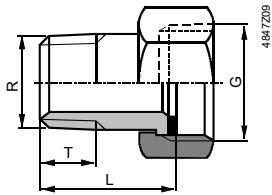

Prod. no. /stock no.	Prod. No. Stock no.	Connection pipe side	G [Inch]	Rp [Inch]
ALG133		External thread	G ½	R ⅜
ALG143		External thread	G ¾	R ½

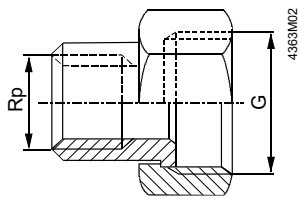

ALG123		Internal thread	G ¾	Rp ⅜
ALG153	ALG153B S55846-Z101	Internal thread	G 1	Rp ½

**Overview fitting combinations
(with V..P47..)**

ALG... type	for valve type	DN	G [inch]	R [inch]	Rp [inch]	L [mm]	T [mm]
ALG132	VVP47.10-0.25...1.6	10	G ½	R ¾		≈ 24	≈ 9
ALG133	VXP47.10-0.25...1.6						
2 x ALG132	VMP47.10-0.25...1.6						
ALG142	VVP47.15-2.5	15	G ¾	R ½		≈ 29.5	≈ 12
ALG143	VXP47.15-2.5						
2 x ALG142	VMP47.15-2.5						
ALG152	VVP47.20-4	20	G 1		Rp ½	≈ 23	≈ 13
ALG152B							
ALG153	VXP47.20-4						
ALG153B							

DN = Nominal size

G = Valve thread (internal cylindrical)

**Conex compression fittings
(for V..P47..S)**

Union nut Compression fitting

Conex 63

Conex 65

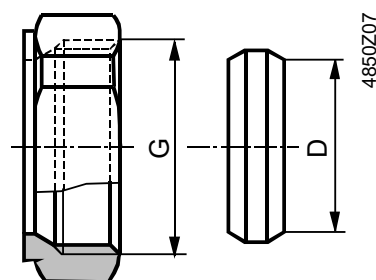

For valve type	k _{vs} - value	DN	G [inch]	Type Conex (from specialist supplier)		D [mm]
				Product-Nr.		
VVP47.10-..S VMP47.10-..S	0.63...1.6	10	G ½	Conex 63 +	E--10CO063-- +	15
				Conex 65	E--10CO065--	
VVP47.15-2.5S VMP47.15-2.5S	2.5	15	W1 ½-14	Conex 63 +	G--10CO063-- +	22
				Conex 65	G--10CO065--	

DN = nominal size

G = valve thread (internal, cylindrical)

D = external diameter for seamless copper and mild-steel piping

Spare parts

Type	Stock No.	Description	Number
S55845-Z182	S55845-Z182 ¹⁾	ALQ1 Protecting Cap M30x1.5	10

¹⁾ Multipack of 10 pieces

Revision numbers

Product number	Valid from manufacturing date	Product number	Valid from manufacturing date	Product number	Valid from manufacturing date
VVP47..	0809 ¹⁾	VXP47..	0809 ¹⁾	VMP47..	0809 ¹⁾

¹⁾ MMY = Month, Year of manufacturing

Issued by:
Siemens Switzerland Ltd
Smart Infrastructure
Global Headquarters
Theilerstrasse 1a
CH-6300 Zug
Switzerland
Tel. +41 58 724-2424
www.siemens.com/buildingtechnologies

© Siemens Switzerland Ltd, 2009
Technical specifications and availability subject to change without notice.