

Electrothermal actuators

STA..21.., STP..21..

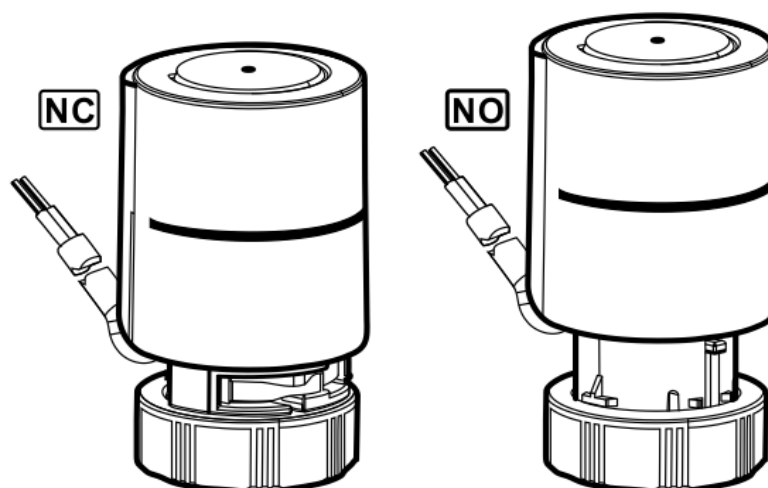

For radiator valves, small valves and PICV

- ST..121.. Operating voltage AC/DC 24 V
- ST..321.. Operating voltage AC 230 V
- Positioning force 110 N
- Connecting cable 1 m / 2 m / 2 m halogen-free / 5 m
- Direct mounting on valve thread M30x1.5 mm
- Closing dimension 10.8 mm (NC), 15.1 mm (NO)
- IP54 Protection degree of housing
- Thermal expansion element
- Low force mounting on the valve by First-Open function
- Robust, maintenance-free
- Degree of pollution, class II
- ST..121.. Rated impulse voltage 1500 V
- ST..321.. Rated impulse voltage 2500 V

- Used in interior rooms.
- For Siemens valves:
 - Radiator valves: VDN.., VEN.., VUN..
 - Small valves: VD1..CLC.., VVP47.., VXP47.., VMP47..
 - Zone valves: VVI46.., VXI46..
 - PICV: VPP46.., VPI46.., VQP46.., VQI46..
 - MiniCombiValves (MCV): VPD.., VPE.., VPU..
- For third-party valves:
 - Direct assembly: Honeywell/MNG, Heimeier, Herz, Comap, Watts (Cazzaniga), Oventrop
 - Assembly with adapter: See Accessories [▶ 6]

Actuator operation

The electrothermal actuators STA.. and STP.. are noise- and maintenance-free.

When the control signal is applied to the actuator, the temperature of the heating element rises, which causes the solid expansion medium to expand. The expansion medium transfers its stroke directly to the installed valve.

The valve starts to open after preheating for approximately 1.5 min if the heating element is switched on while cold (room temperature), and achieves the maximum stroke after approximately another 2 min (AC 230 V) or 3 min (AC/DC 24 V).

At power-off, the expansion element cools down and the valve will be closed by the actuator spring.

	NC (Normally Closed)	NO (Normally Open)
Actuators	STA..21..	STP..21..
De-energized	<ul style="list-style-type: none"> ● Actuator stem is extended. ● Valve (NO) is closed. 	<ul style="list-style-type: none"> ● Actuator stem is retracted. ● Valve (NC) is closed by its own spring.
Behavior at power-on	<ul style="list-style-type: none"> ● Actuator stem retracts. ● Valve (NO) is opened by its own spring. 	<ul style="list-style-type: none"> ● Actuator stem extends. ● Valve (NC) is opened.
Valve	Example: <ul style="list-style-type: none"> ● Radiator valves (V..N..) ● Small valves (VD1..CLC) ● Zone valves (V..I46..) ● PICV (VP..46.., VQ..46) 	Typical examples: <ul style="list-style-type: none"> ● Small valves (V..P47..)
Without actuator	<ul style="list-style-type: none"> ● Valve is opened without actuator. ● Valve stem is extended. 	<ul style="list-style-type: none"> ● Valve is closed without actuator. ● Valve stem is extended.

First Open function

The NC version has a First-Open function, that is activated in the delivery state. The First-Open function is used to mount the actuator on the valve with little force and for flushing the plant before commissioning. The First-Open function is deactivated during initial startup and the actuator opens and closes as intended.

To reactivate the first-open function, e.g. before disassembly, the drive can be moved to the open position using a screwdriver or locked in the energized open state (see mounting instructions).

Definition NC/NO

Version **NC** «normally closed»:

After mounting the actuator, the valve is closed in the idle state. When voltage is applied to the actuator, the actuator stem retracts and the valve is opened.

Valve state with voltage-free actuator: closed.

NC STA..21..

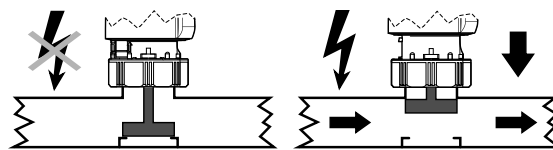

Version **NO** «normally open»:

After mounting the actuator, the valve is open in the idle state. When voltage is applied to the actuator, the actuator stem extends and the valve is closed.

Valve state with voltage-free actuator: open.

NO STP..21..

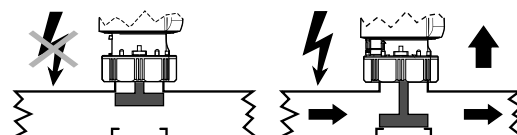

Definition closing dimension

Closing dimension adapter ¹⁾			
	A	B	
VUN..	10.8	⇒	-
VPD.., VPE.., VPU..	10.8	⇒	-
VVP47.., VXP47.., VMP47..	10.8	⇒	-
VXI46.25T..	10.8	⇒	-
VDN.., VEN..	10.2	⇒	A
VD1..CLC..	10.2	⇒	A
VVI46.., VXI46..	10.2	⇒	A
VQP46.., VQI46..	8.4	⇒	B
VPP46.10L0.2	10.8	⇒	-
VPP46.10L0.4	8.4	⇒	B
VPP46.15.., VPI46.15..	10.8	⇒	-
VPP46.20.., VPI46.20..	8.4	⇒	B
VPP46.25.., VPI46.25..	8.4	⇒	B
VPP46.32.., VPI46.32..	8.4	⇒	B

¹⁾ Included in delivery

NC STA..21..

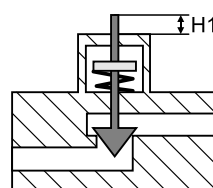

	H1 [mm]
STA..21..	10.8
STA..21.. + A	10.2
STA..21.. + B	8.4

NO STP..21..

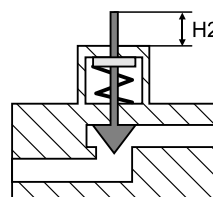

	H2 [mm]
STP..21..	15.1
STP..21.. + A	14.5
STP..21.. + B	12.7

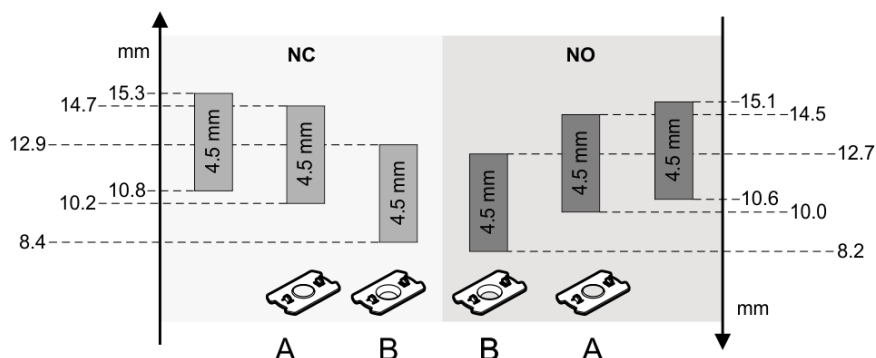



The valve is closed in a de-energized state for most valve applications featuring thermal actuators.

Actuators with the opposite control action are used when the reverse function is required: The valve is opened in a de-energized state.

⇒ **NO function: STA.. + NC valve / STP.. + NO valve**

Response at de-energized actuator			
Valve	Type	STA..21..	STP..21..
Radiator valves	VDN.., VEN.., VUN..	Closed	Open ^{1), 2)}
Small valves	VD1..CLC..	Closed	Open ^{1), 2)}
	VVP47.., VPI47.., VMP47..	A ↔ AB open ^{1), 2)}	A ↔ AB closed
Zonen valves	VVI46.., VXI46..	AB ↔ A closed	AB ↔ A open ^{1), 2)}
PICV	VPD.., VPE.. VPP46.., VPI46.. VQP46.., VQI46..	Closed	Open ^{1), 2)}

1) Controller must support NO valve actuator combinations.

2) Combination no recommended, as it makes no sense in terms of energy outside of demand period.

Positioning times, opening / closing

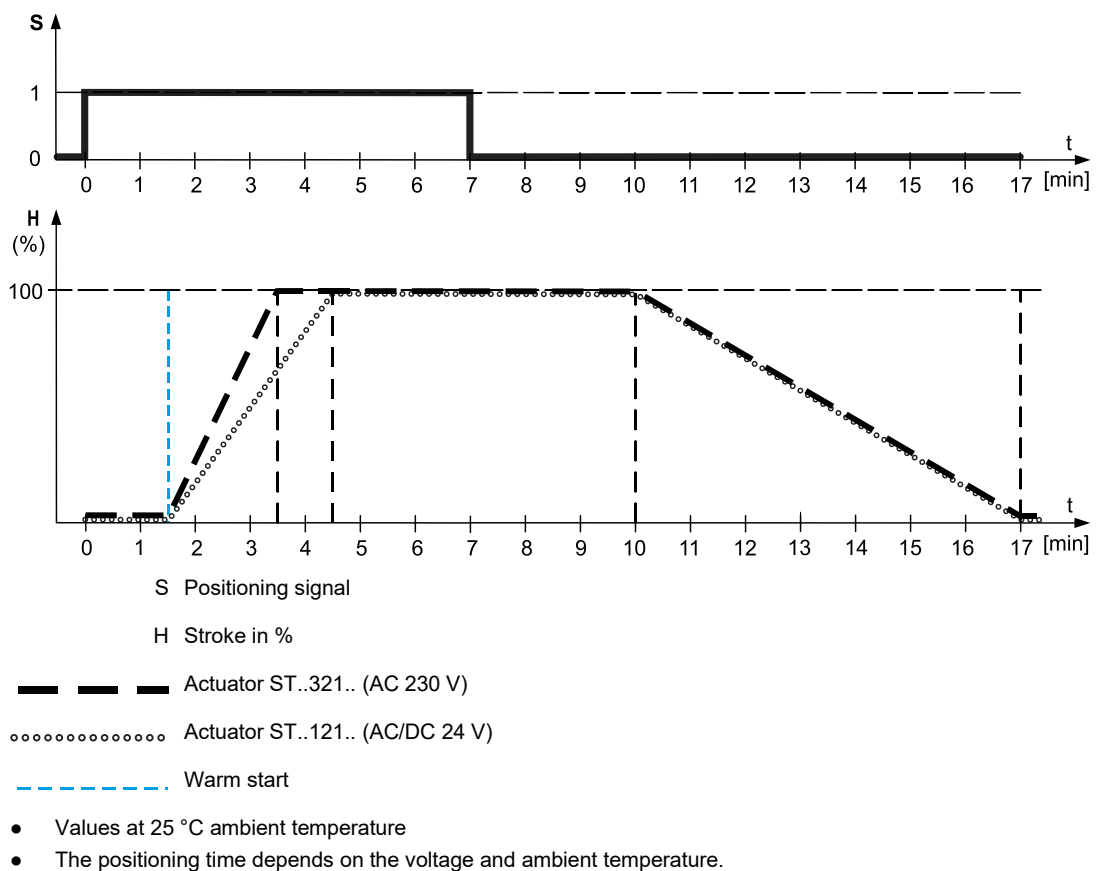



Some controllers drive the thermal valve actuators via PDM/TPI signals. This increases the response time. For optimal control, the ambient temperature must be <40 °C.



Position indication

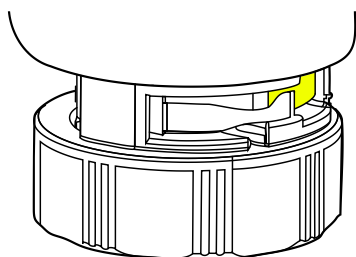

The movement and actual position of the actuator stem is indicated by the yellow stroke indicator.

The yellow part indicates:

- The actuator stem is extended.
- NC valve is closed.
- NO valve is opened.

Type summary

Type	Stock no.	Position de-energized ¹⁾	Operating voltage	Positioning time	Connecting cable
STA121	S55174-A177	NC	AC/DC 24 V	270 s	1 m
STA121.L20	S55174-A181				2 m
STA121.L20H ²⁾	S55174-A195				2 m
STA121.L50	S55174-A185				5 m
STA321	S55174-A178		AC 230 V	210 s	1 m
STA321.L20	S55174-A182				2 m
STA321.L20H ²⁾	S55174-A196				2 m
STA321.L50	S55174-A186				5 m
STP121	S55174-A179	NO	AC/DC 24 V	270 s	1 m
STP121.L20	S55174-A183				2 m
STP121.L50	S55174-A187				5 m
STP321	S55174-A180		AC 230 V	210 s	1 m
STP321.L20	S55174-A184				2 m
STP321.L50	S55174-A188				5 m

¹⁾ NC = Normally Closed = (valve) powerless closed
NO = Normally Open = (valve) powerless opened

²⁾ Halogen-free per VDE 0207-24

Scope of delivery

Actuators, valves and accessories are packaged and delivered separately.

Ordering example

Type	Stock no.	Designation	No. of pieces
STA121.L20	S55174-A181	Electrothermal actuator	1
AV53	BPZ:AV53	Third-party valve adapter on Danfoss RA-N (RA2000)	1

Note: Closing dimension adapters A & B are included in the scope of delivery

Accessories

Adapter for third-party valves

Type	Stock no.	For third-party valves from
AV52	BPZ:AV52	Comap
AV53	BPZ:AV53	Danfoss RA-N
AV54	BPZ:AV54	Danfoss RAVL
AV56	BPZ:AV56	Giacomini
AV59	BPZ:AV59	Vaillant

Spare parts

Adapter for Definition closing dimension

Type	Stock no.	Designation	No. of pieces
ADA10	S55174-A199	Closing dimension adapter for Electrothermal actuators STA/STP	10 (10 x type A and 10 x type B)

Equipment combinations

Siemens valves

Type	Valve type	Actuator	k_{vs} [m ³ /h]	\dot{V} [l/h]	PN class	Data sheet
VDN.., VEN.., VUN..	Radiator valves	STA..	0.09...1.41	-	PN 10	N2105, N2106
VPD.., VPE.., VPU..	MCV MiniCombiValves	STA..	-	25...483		N2185
VD1..CLC..	Small valves	STA..	0.25...2.6	-		N2103
VVI46.., VXI46..	Zone valves	STA..	2...5	-	PN16	N4842
VVP47.., VXP47.., VMP47..	Small valves	STP..	0.25...4	-		N4847
VPP46.., VPI46..	PICV	STA.., STP...	-	30...3400	PN25	N4855
VQP46.., VQI46..	PICV	STA..	-	30...1800		A6V11877580

k_{vs} Nominal flow for cold water (5...30 °C) through a fully opened valve (H_{100}), at a differential pressure of 100 kPa (1 bar)

\dot{V} Volumetric flow at 0.5 mm stroke

Third-party valves, without adapter (M30x1.5)

- Honeywell/MNG
- Comap
- Herz
- Heimeier
- Watts (Cazzaniga)
- Oventrop

Third-party valv with adapter

See Accessories [6] above

Title	Content	Document ID
Electrothermal actuators STA..21.., STP..21..	Data sheet: Product description	A6V12986007
	Mounting instructions	A5W00214679A (A6V12984110)
Valves		
Radiator valves VDN1.., VEN1..	Data sheet: Product description	N2105
Radiator valves VDN2.., VEN2.., VUN2..		N2106
MiniCombiValves (MCV) VPD.., VPE..		N2185
Small valves VD1..CLC..		N2103
2-port and 3-port zone valves PN16 VVI46.., VXI46..		N4842
2-port and 3-port terminal unit valves PN16 VVP47.., VXP47.., VMP47..		N4847
PICV PN25 VPP46.., VPI46..		N4855
On/Off PICV PN25 VQP46.., VQI46..		A6V11877580

Notes

Safety

 CAUTION



National safety regulations

Failure to comply with national safety regulations may result in personal injury and property damage.

- Observe national provisions and comply with the appropriate safety regulations.

 CAUTION



Risk of injury from electric shock

- Do not use the device with a defective cable.
- Disconnect the device from power prior to assembly or disassembly.
- Do not attach to hot pipes.
- Use an external fuse to protect the device
- Use a transformer or power supply compliant with safety extra-low voltage requirements as per IEC 60730-1 as well as IEC 61558-2-6 or IEC 61558-2-16.2 to supply the variants carrying 24 V.

Mounting

The mounting instructions A5W00214679A are included in the package.

Mounting positions

The actuators may be installed in all positions.
IP54 remains guaranteed.

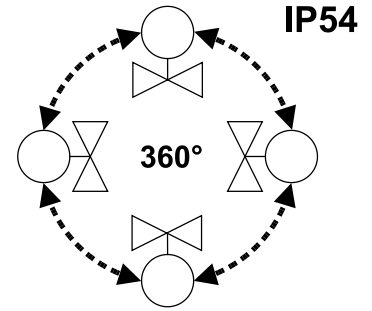

Mounting on the valve

- ⇒ Disconnect the device from the power supply before assembly.
- ✓ Do not use tools like pipe wrenches or spanners.
- a) Remove the protective cover from the valve body.
- b) If necessary, insert a closing dimension adapter.
- c) Place the actuator on the valve and tighten the screw cap by hand.
- ⇒ After successful assembly, connect to the operating voltage.

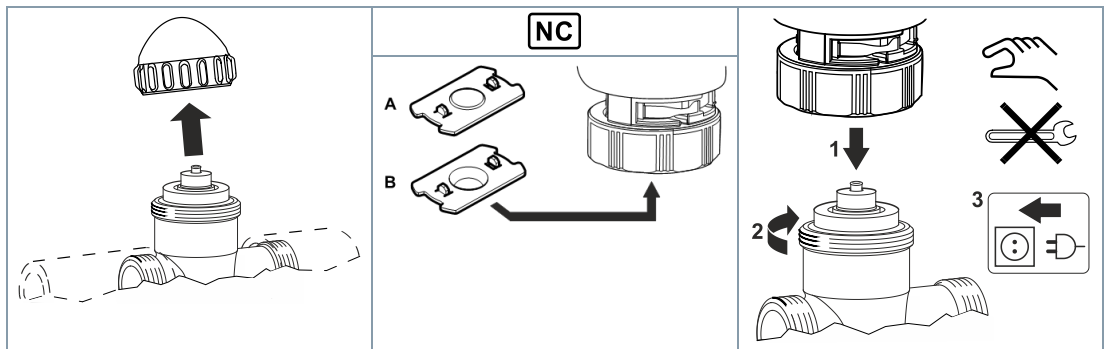

Dismounting

- ⇒ ⚠ Disconnect the device from the power supply before disassembly.
⇒ Note NC-variants – reactivate First-Open function.
- ✓ ⚠ Attention! The device and/or pipes may still be hot. Wait until the device has cooled down.
- a) For NC variants STA..21...:
First Open function: Reset to the First Open position.
- Raise the coverlet in the opening with a screwdriver, until a clicking sound is heard and the lever is back on the front.
- b) Loosen the screw cap by hand and remove the actuator from the valve.

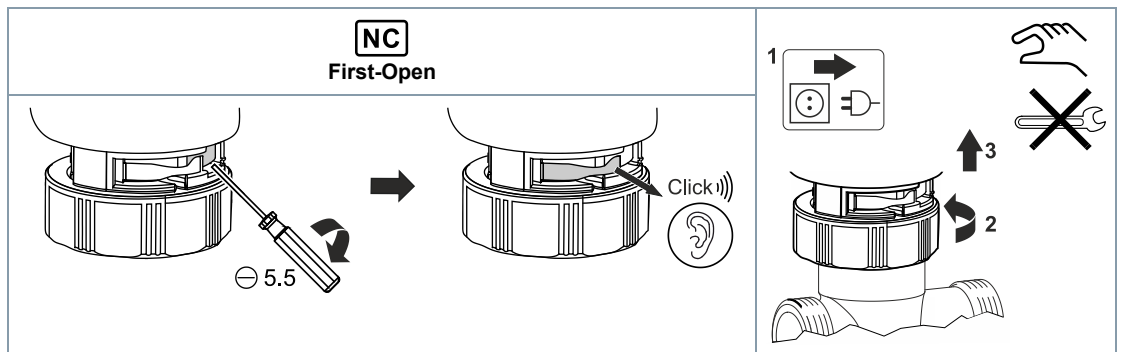

Maintenance

The actuators STA..21.. and STP..21.. are maintenance-free.

Disposal

	<p>The device is considered an electronic device for disposal in accordance with the European Guidelines and may not be disposed of as domestic garbage.</p> <ul style="list-style-type: none">• Dispose of the device through channels provided for this purpose.• Comply with all local and currently applicable laws and regulations.
--	---

Warranty

The application-specific technical data is guaranteed only in combination with the Siemens products listed in the 'Device combinations' section. If third-party products are used, any guarantee provided by Siemens will be invalidated.

Power supply			
Operation voltage	ST..121..		AC/DC 24 V +/-20 %, 50...60 Hz (AC version)
	ST..321..		AC 230 V +/-15 %, 50...60 Hz
Power consumption	ST..121..		1.6 W
	ST..321..		1.7 W
Inrush current	ST..121..		200 mA
	ST..321..		150 mA
	Switch-on power 24 V~/=		5 W / 5 VA
	Switch-on power 230 V~		35 W / 35 VA
Rated impulse voltage	ST..121.. (24 V variants)		1500 V
	ST..321.. (230 V variants)		2500 V
Connecting cable	Length	STA121, STA321 STP121, STP321	1 m
		ST..L20..	2 m (also halogen-free)
		ST..L50	5 m
	Cross-section	2 x 0.75 mm ²	

Functional data		
Positioning time	ST..121..	270 s
	ST..321..	210 s
Positioning force	110 N	
Nominal stroke	Max. 4.5 mm	
	Closing dimension 10,8 mm for NC actuator Closing dimension 15,1 mm for NO actuator	
Permissible medium temperature	1...100 °C	

Degree of protection		
Protection class	ST..121.. (AC/DC 24 V)	III as per IEC 60730-1
	ST..321.. (AC 230 V)	II as per IEC 60730-1
Protection degree of housing	IP54 per EN 60529	

Environmental conditions		
Operation	Temperature	0...50 °C
	Humidity (non-condensing)	<85% r.h.
Transportation, storage	Temperature	-25...70 °C
	Humidity (non-condensing)	<85% r.h.

Directives and standards	
Product standard	IEC 60730-1 and IEC 60730-2-14
Low Voltage Directive 2014/35/EU	EN 60730-1:2011 EN 60730-2-14:1997 + A1:2001 + A11:2005 + A2:2008
RoHS- Directive 2011/65/EU	EN IEC 63000:2018
EMC-Directive 2014/30/EU	EN 60730-1:2011 EN 60730-2-14:1997 + A1:2001 + A11:2005 + A2:2008
EAC	Eurasia compliance
UKCA	Great Britain conformity A5W00236924A
EU	European Union Conformity A5W00236920A

Environmental compatibility
Product environmental declaration A6V13037506 ¹⁾ (STA..21..) and A6V13246399 ¹⁾ (STP..21..) contain data on environmentally compatible product design and assessments (RoHS compliance, materials composition, packaging, environmental benefit, disposal).

Dimensions	
Thread	M30x1.5
W x H x D	See Dimensions [► 12]
Weight	

¹⁾ Documents are available at <http://www.sid.siemens.com>

Connection diagrams

Internal Diagrams

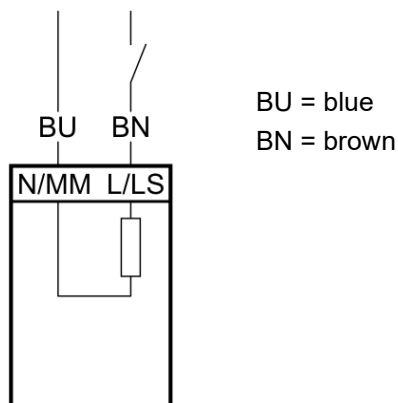

Dimensions

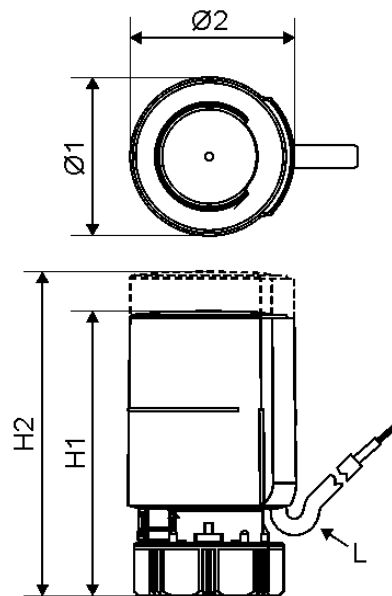

Type	$\varnothing 1$	$\varnothing 2$	H1 (NC)	H2 (NO)	L	kg
	[mm]					[kg]
STA..21..	39	40.5	68	-	>32	0.10
STP..21..			-	72		

Revision no.

Type	Item number	Valid from rev. no.	Type	Item number	Valid from rev. no.
STA121	S55174-A177	..A	STP121	S55174-A179	..A
STA121.L20	S55174-A181	..A	STP121.L20	S55174-A183	..A
STA121.L20H	S55174-A195	..A	STP121.L50	S55174-A187	..A
STA121.L50	S55174-A185	..A	STP321	S55174-A180	..A
STA321	S55174-A178	..A	STP321.L20	S55174-A184	..A
STA321.L20	S55174-A182	..A	STP321.L50	S55174-A188	..A
STA321.L20H	S55174-A196	..A			
STA321.L50	S55174-A186	..A			