

OpenAir™

Air Damper Actuator Modbus RTU

GEB161.1E/MO, 20 Nm, Non-spring return type



Damper actuator 20 Nm (non-spring return) with Modbus communication

- Nominal torque 20: Nm
- Modbus RTU communication
- Operating voltage: AC/DC 24 V
- For air-handling units (AHU) and other ventilation applications

Functions

Function	Description
Communication	Modbus RTU (RS-485), not galvanically separated
Functions	- Setpoint and actual position 0..100% - Override control Open / Close / Min / Max / Stop - Setpoint monitoring and backup mode
Supported baudrates	9.6, 19.2, 38.4, 57.6, 78.4, 115.2 kbaud
Supported transmission formats	1-8-E-1, 1-8-N-1-, 1-8-O-1, 1-8-N-2
Termination	120 Ω electronically switchable

Type summary

Product no.	Stock no.	Operating voltage	Positioning signal	Power consumption	Posit. time	Manual adjuster	Position feedback
GEB161.1E/MO	S55499-D663	AC/DC 24 V	Modbus RTU	2.6 VA / 1.7 W max. ¹⁾	150 s	Yes	Yes

¹⁾ max. = actuator rotates

Accessories / Spare parts

Please refer to data sheet N4697.

Ordering (Example)

Product no.	Stock no.	Description	Amount
GEB161.1E/MO	S55499-D663	Damper actuator Modbus	1
+ accessories (shaft inserts, etc.)			

Equipment combinations

Product no.	Stock no.	Doc. type	Doc. number
POL424.50/STD	S55394-C245-A100	Datasheet	Q3973
POL424.70/STD	S55394-C247-A100	Operating manual	P3973
POL635.00/STD	BPZ:POL635.00/STD	Datasheet	Q3230
		Operating manual	P3903
POL638.00/STD	BPZ: POL638.00/STD	Datasheet	Q3900
POL638.70/STD	S55396-C387-A100	Operating manual	P3903

Product documentation

Title	Topic	Document ID
Climatix AHU Application	Application description	A3975
Installation Instruction	Installation of types with external Modbus interface	A6V101006034

Related documents such as environmental declarations, CE declarations, etc., can be downloaded at the following Internet address: <http://siemens.com/bt/download>

Safety

⚠ CAUTION
National safety regulations

Failure to comply with national safety regulations may result in personal injury and property damage.

- Observe national provisions and comply with the appropriate safety regulations.

Mounting

Note: Do not open the damper actuators

Mounting positions

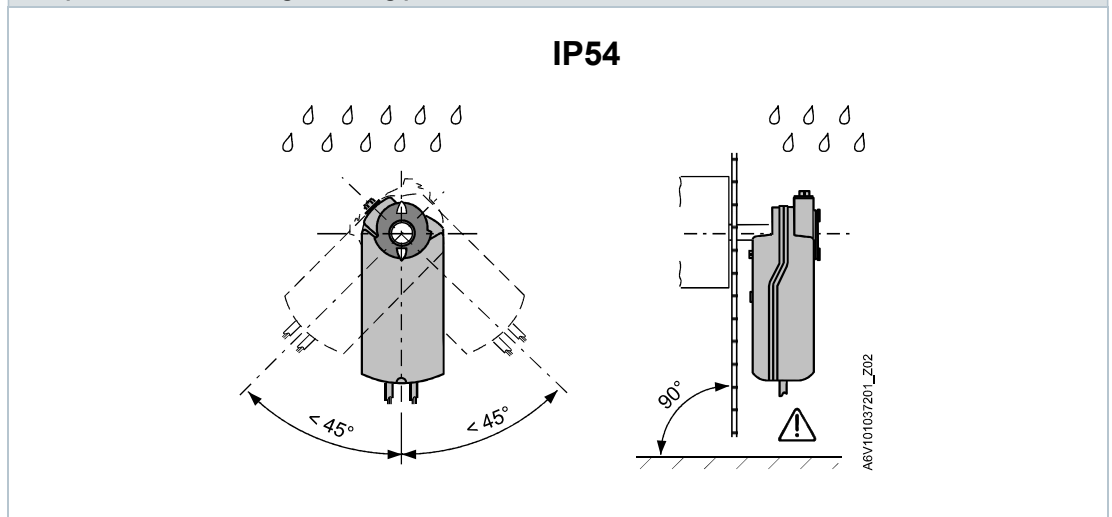
IP54 protection in following mounting positions

Commissioning

Workflow 1

The devices are especially designed for using the Climatix push-button configuration as described in document A3975 ¹⁾. The bus configuration can alternatively be parameterized by the local HMI, cf. page 5.

During commissioning check/set the following:

- Bus configuration (address, baudrate, transmission mode, and optionally termination). The default address 255 allows to mount and power multiple actuators at the same time without interfering with each other.
- Damper actuator parameters (opening direction, position limits, position adaptation etc.) can be checked via the Modbus register.

¹⁾ The documents can be downloaded from <http://siemens.com/bt/download>

Workflow 2

The devices can be configured over bus if the pre-commissioning settings allow for a connection between the Modbus master / programming tool and peripheral devices (i.e. non-conflicting addresses and matching baudrate / transmission format).

- Full configuration over bus: If the address is unique per segment when powered up, the device can be accessed by the Modbus master (or programming tool) and the address and other parameters can then be set to the definitive values.
- Partial configuration over bus: If the address is not unique per segment when powered up, each device must get a non-conflicting address before connecting it to the bus, either by using the address input with push button (cf. page 6) or by setting the address to 246 with push button press > 5s und < 10s (cf. page 5). After addressing all devices, the remaining configuration can be done over the bus using the default settings for baudrate (auto-baud) and transmission mode for the Modbus master.
- Overwriting the bus configuration over bus uses a timeout. If „1 = Load“ is not written into Reg 768 within 30 seconds, all values are discarded.

Example: Table shows bus configuration registers before and after changing them over bus.

Reg.	Name	Pre-commissioning	New value (ex.)
764	Modbus Address	246	12
765	Baudrate	0 = auto	1 = 9600
766	Transmission Format	0 = 1-8-E-1	3 = 1-8-N-2
767	Termination	0 = Off	0 = Off
768	Bus Conf. Command	0 = Ready	1 = Load

Maintenance

The damper actuators are maintenance-free.

Disconnect the electrical connections from the terminals if you want to work at the device.

Disposal



The device is considered an electronics device for disposal in terms of European Directive 2012/19/EU and may not be disposed of as domestic garbage.

- Dispose of the device through channels provided for this purpose.
- Comply with all local and currently applicable laws and regulations.

Warranty

Technical data on specific applications are valid only together with Siemens products listed under "Equipment combinations". Siemens rejects any and all warranties in the event that third-party products are used.

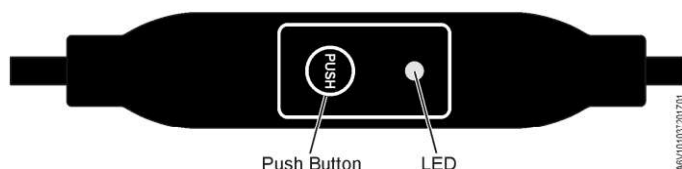

Push-button operation

Activity	Push-button operation	Confirmation
Display current address (starting with lowest address digit)	Press button < 1s	1-digits: red 10-digits: green 100-digits: orange If termination is switched on, LED flashes 1x blue after address display Example: 124 = 4x red, 2x green, 1x orange
Turn bus termination on / off	<p>turn on</p> <ol style="list-style-type: none"> 1. press 3x 2. press 1x shortly 3. press button until LED shines red 4. release button <p>turn off</p> <ol style="list-style-type: none"> 1. press 3x 2. press button until LED shines red 3. release button 	<p>LED flashing and flickering stops (termination mode)</p> <p>LED flashes 1x blue</p> <p>LED shines red (confirmation)</p> <p>LED off</p> <p>Address display</p> <p>LED flashes 1x blue after address display</p> <p>Normal operation</p> <p>LED flashing and flickering stops (termination mode)</p> <p>LED shines red (confirmation)</p> <p>Normal operation</p>
Enter Modbus address with push-button	Press button > 1s and < 5s	See chapter 'Push-button addressing' below
Enter push-button addressing mode (for use with Climatix™ controllers)	<ol style="list-style-type: none"> 1. Press button > 5s and < 10s 2. Release button 	LED shines red and gets dark after 5s LED shines orange
Reset to factory settings	Press button > 10s	LED flashes orange

LED colors and patterns

Color	Pattern	Description
Green	1s on / 5s off	Normal operation ("life pulse") without bus traffic
	flashing	Normal operation ("life pulse") with bus traffic
Orange / green	1s orange / 1s green	Device is in override control
Orange	1s on / 1s off	Bus parameters not yet configured
	1s on / 5s off	Backup mode entered
Red	Steady	Mechanical fault, device jammed or manual override
	1s on / 5s off	Internal error
	0.1s on / 1s off	Invalid configuration, e.g. Min = Max
Blue	Flashes 1x after address display	Bus termination is set active.

Resetting the device by push button

1. Press button for >10s → LED starts flashing **orange**
2. Release button while LED still flashes → LED keeps flashing for 3s
3. If the button is pressed within these 3s, the reset is cancelled.
4. After those 3s → LED shines **red** (reset), then the device restarts.

Push-button addressing

Display current address (starting with lowest address digit)

The Modbus address can be set without a separate tool by using the push-button and LED.

To display the current address, press button <1s.

Colors		
1-digits: red	10-digits: green	100-digits: orange

Example for address 124:

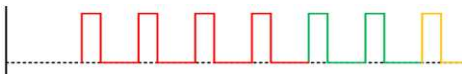
LED	
Note	The address is entered and shown starting with lowest address digit, see figure above. (124 in the example is starting with 4x red)

Set new address (starting with lowest address digit)

1. **Enter addressing mode:** press button > 1s until LED shines **red**, then release button (before LED gets dark).
2. **Enter digits:** press button n-times → LED flashes per button press (feedback).
Colors: 1-digits: **red** / 10-digits: **green** / 100-digits: **orange**
3. **Store digits:** press button until LED shines in color of following digits – release button,
4. **Save address:** press button until LED shines **red** (confirmation) → release button.
An address can be stored at any time, i.e. after setting the 1-digits, or after setting the 1- and the 10-digits.
5. Entered address is repeated one times for confirmation.

Note: If button is released before LED shines red, the address is discarded.

Examples

Set address "124":

1. Enter addressing mode
2. Set 1-digits: Press button 4-times → LED flashes **red** per button press
3. Store 1-digits: press button until LED shines **green** – release button
4. Set 10-digits: Press button 2-times → LED flashes **green** per button press
5. Store 10-digits: press button until LED shines **orange** – release button
6. Set 100-digits: Press button 1-times → LED flashes **orange** per button press
7. Store address: press button until LED shines **red** – release button
→ address is stored and displayed 1x for confirmation

Set address "50":

1. Enter addressing mode
2. Skip 1-digits: Hold button pressed until LED shines **green** – release button
3. Set 10-digits: Press button 5-times → LED flashes **green** per button press
4. Store address (skip 100-digits): hold button pressed until LED shines **red** – release button
→ address is stored and displayed 1x for confirmation

Set address "5":

1. Enter addressing mode
2. Set 1-digits: Press button 5-times → LED flashes **green** per button press
Store address: press button until LED shines **red**
→ address is stored and displayed 1x for confirmation

Modbus registers

Reg.	Name	R/W	Unit	Scaling	Range / enumeration
Process Values					
1	Setpoint	RW	%	0.01	0..100
2	Override control	RW	--	--	0 = Off / 1 = Open / 2 = Close 3 = Stop / 4 = GoToMin / 5 = GoToMax
3	Actual position	R	%	0.01	0..100
256	Command	RW	--		0 = Ready / 1 = Adaption / 2 = Selftest 3 = ReInitDevice / 4 = RemoteFactory Reset

Parameters					
257	Opening direction	RW	--	--	0 = CW / 1 = CCW
258	Adaptive Mode	RW	--	--	0 = Off / 1 = On
259	Operating Mode	RW	--	--	1 = POS
260	MinPosition	RW	%	0.01	0..100
261	MaxPosition	RW	%	0.01	0..100
262	Actuator Running Time	R	s	1	150
513	Backup Mode	RW	--	--	0 = Go to BackupPosition 1 = Keep last position 2 = Disabled
514	Backup Position	RW	%	0.01	0..100
515	Backup Timeout	RW	s	1	0..65535
516	Startup Setpoint	RW	%	0.01	0..100
764	Modbus Address	RW	--	--	1..247 / 255 = "unassigned"
765	Baudrate	RW	--	--	0 = auto / 1 = 9600 / 2 = 19200 3 = 38400 / 4 = 57600 / 5 = 76800 6 = 115200
766	Transmission Format	RW	--	--	0 = 1-8-E-1 / 1 = 1-8-O-1 2 = 1-8-N-1 / 3 = 1-8-N-2
767	Bus Termination	RW	--	--	0 = Off / 1 = On
768	Bus Conf. Command	RW	--	--	0 = Ready / 1 = Load / 2 = Discard
769	Status	R	--	--	See below, Register 769 "Status"

Device information					
1281	Factory Index	R	--	--	Cf. product documentation Z4621 / Z4626 ¹⁾
1282-83	Factory Date	R	--	--	
1284-85	Factory SeqNo	R	--	--	
1409-16	TypeASN [Char_16..1]	R	--	--	

¹⁾ The documents can be downloaded from <http://siemens.com/bt/download>

Register 769 "Status"

Status			
Bit 00	1 = reserved	Bit 06	1 = Adaption done
Bit 01	1 = Backup mode active	Bit 07	1 = Adaption in progress
Bit 02	1 = reserved	Bit 08	1 = Adaption error
Bit 03	1 = reserved	Bit 09	1 = Selftest failed
Bit 04	1 = Mechanical fault, device jammed or manual override	Bit 10	1 = Selftest passed
Bit 05	1 = Nom. lifetime exceeded	Bit 11	1 = Invalid configuration

Supported function codes

Function codes	
03 (0x03)	Read Holding Registers
04 (0x04)	Read Input Registers
06 (0x06)	Write Single Register
16 (0x10)	Write Multiple registers (Limitation: Max. 120 registers within one message)

Technical data

Power supply		
Operating voltage		AC/DC 24 V ± 20 % (SELV) or AC 24 V class 2 (US)
Frequency		50/60 Hz
Power consumption at 50 Hz	Running	2.6 VA / 1.7 W
	Holding	2.3 VA / 1.1 W
Function data		
Running time for rotary angle 90°(motor operation)		150 s
Nominal torque		20 Nm
Maximum torque (blocked)		35 Nm
Nominal / maximum rotation angle		90° / 95° ± 2°
Direction of rotation	Adjustable over bus	Clockwise (CW) / Counter-clockwise (CCW)
Communication		
Communication protocol	Modbus RTU	RS-485, not galvanically separated
	Number of nodes	Max. 32
	Address range	1...247 / 255 Default: 255
	Transmission formats	1-8-E-1 / 1-8-O-1 / 1-8-N-1 / 1-8-N-2 Default: 1-8-E-1
	Baudrates (kBaud)	Auto / 9.6 / 19.2 / 38.4 / 57.6 / 76.8 / 115.2 Default: Auto
	Termination	120 Ω electronically switchable Default: Off
Connection cables		
Cable length		0.9 m
Power supply / Communication	Number of cores and cross-sectional area	5 x 0.75 mm ²
Degree of protection		
Degree of protection	Degree of protection acc. to EN 60529 (see also chapter 'Mounting' above)	IP54
Safety class	Safety class acc. to EN 60730	III
Environmental conditions		
Applicable standard		IEC 60721-3-x
Operation	Climatic conditions	Class 3K5
	Mounting location	Indoors
	Temperature general	-32...55 °C
	Humidity (non condensing)	< 95 % r. h.
Transport	Climatic conditions	Class 2K2
	Temperature	-32...70 °C
	Humidity	< 95 % r. h.
Storage	Climatic conditions	Class 1K3
	Temperature	-5...45 °C
	Humidity	< 95 % r. h.

Directives and Standards	
Product standard Electromagnetic compatibility (Application)	EN60730-x For residential, commercial and industrial environments
EU Conformity (CE)	A5W00004376 ¹⁾
UKCA Conformity	A5W00198170A ¹⁾
RCM Conformity	A5W00004377 ¹⁾
EAC Conformity	Eurasia conformity for all G..B variants

Environmental compatibility	
The product environmental declarations A5W00055607 (GEB) ¹⁾ , and A6V101083254en (external Modbus interface) ¹⁾ contain data on environmentally compatible product design and assessments (RoHS compliance, materials composition, packaging, environmental benefit, disposal).	

Dimensions / Weight	
Weight (w/o packaging)	1.2 kg
Dimensions (w/o bus interface)	82 x 192 x 63 mm
Suitable drive shafts	Round / square shaft
	Min. drive shaft length
	8...20,5 mm / 8... 14,5 mm
	20 mm

¹⁾ The documents can be downloaded from <http://siemens.com/bt/download>

Diagrams

Internal diagrams

The damper actuators are supplied with a prewired connecting and communication cable. All interconnected devices must be connected to the same G0.

Core desig.	Core color	Terminal code	Description
1	red (RD)	G	System voltage AC 24 V
2	black (BK)	G0	System neutral AC 24 V
6	violet (VT)	REF	Reference (Modbus RTU)
8	grey (GY)	+	Bus + (Modbus RTU)
9	pink (PK)	-	Bus - (Modbus RTU)

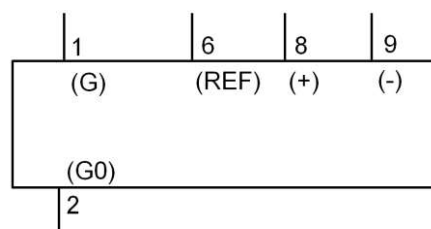

Note

The operating voltage at terminals G and G0 must comply with the requirements under SELV or PELV. Safety transformers with twofold insulation as per EN 61558 required; they must be designed to be on 100 % of the time.

Dimensions

Actuator

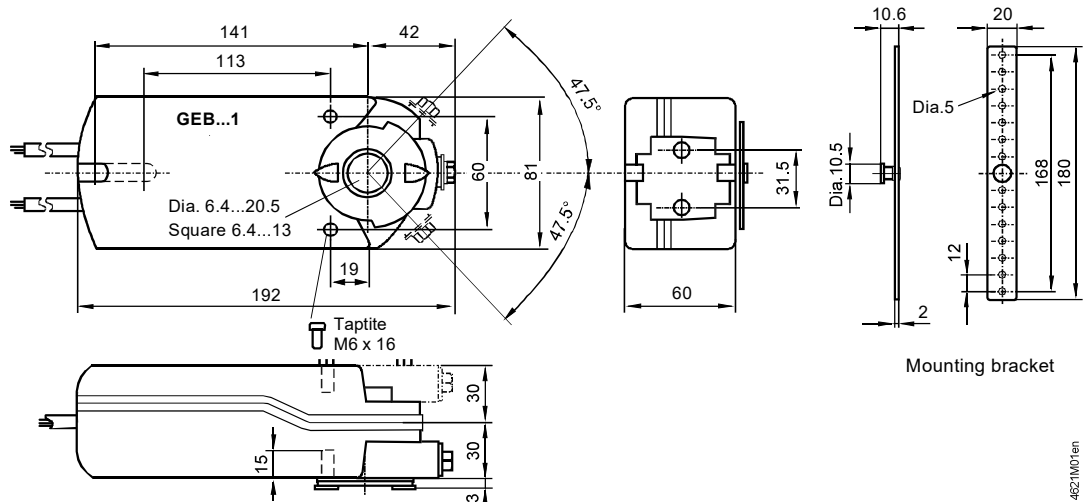

4621M01/en

a External Modbus Interface

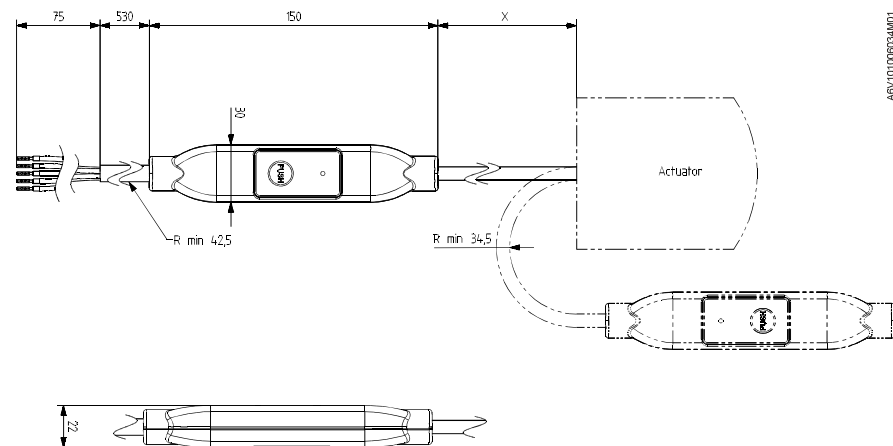

X = 220 mm

Dimensions in mm

Issued by
Siemens Switzerland Ltd
Smart Infrastructure
Global Headquarters
Theilerstrasse 1a
CH-6300 Zug
Tel. +41 58 724 2424
www.siemens.com/buildingtechnologies

© Siemens Switzerland Ltd, 2021 - 2024
Technical specifications and availability subject to change without notice.